



Safely Remove Toxic and Combustible Dusts From Your Factory or Shop

The Gold Series X-Flo (GSX) dust collector is the industry's best-in-class dust collection system. It's built on 20 years of successful performance of our award-winning Farr Gold Series® system. It handles all kinds of toxic and combustible dusts and fumes, including fine, fibrous and heavy dust loads.

GSX dust collectors effectively process dust while maintaining a low pressure drop. You get the maximum airflow and dust processing power for any given footprint.

GSX collectors use crossflow technology and a unique baffle configuration to create a uniform airflow that extends the life of your filters. Filter cartridges last longer and require fewer changeouts, reducing the total cost of ownership.

- **Modular construction – easy to build and assemble in limitless sizes and configurations**
- **Tested to meet NFPA & ATEX standards**
- **Available with numerous explosion protection options**
- **Exceeds OSHA mandates for factory air quality**
- **Less pulsing of filter cartridges is necessary, so the filters last longer and require less changeouts**
- **Smaller footprints are possible because each unit handles more airflow**
- **Ships in as few pieces as possible for fast delivery**
- **Easy installation, operation and maintenance**
- **Built on 20 years of reliable field dust collection performance**



More filter media, same footprint

We designed the inlet, filter cartridges and filter position so each housing module can accommodate larger cartridges without increasing the overall footprint.

Each module holds four cartridges of HemiPleat® filter media and can handle airflows up to 6,000 cfm while maintaining a low pressure drop.



Customizable configurations



Four filters per module

Solves Dust and Fume Problems Across Many Industries and Applications

GSX dust collectors are ideal for most industrial applications that produce or process fine, fibrous and heavy dusts and fumes. Industries that benefit the most include pharmaceutical, mining, food processing, chemical processing, and metalworking applications like welding, thermal spray, plasma cutting, laser cutting, and abrasive blasting.



SHOWN WITH OPTIONAL iSMF
(Integrated Safety Monitoring Filter)
isolates downstream equipment from
the progression of a flame front in the
event of a combustible dust explosion.

Heavy duty 7 & 10-gauge
steel construction.

Each module can
process more dust
and move more air
through the filters
while maintaining a
low pressure drop.

The housing module
accommodates larger
filter cartridges
without increasing
the footprint.

Newly engineered
inlet channels more
dust straight to the
hopper instead of
into the filters.

The larger, lighter-weight
door provides a bigger
entrance for filter access,
while maintaining explosion
rating requirements.

Gold Cone X-Flo Filter
vertical cartridges have more
downward-facing media than
any other filter on the market,
which doubles the airflow
through the cone.

Powder-coated inside and out
for maximum durability.

Crossflow technology combined
with a unique baffle configuration
creates a uniform airflow that
extends the life of your filters.

Combustible dust explosions are a serious risk at many manufacturing, processing and metalworking plants. An unprotected dust collection system can be a main cause. Gold Series X-Flo dust collectors help mitigate these risks because they are configured to your unique situation.

Safe and Compliant

GSX dust collectors exceed OSHA mandates for indoor air quality. They are tested to meet NFPA & ATEX standards and available with many explosion protection options including explosion vents, isolation valves, integrated safety monitoring filters, and fire-retardant filter cartridges.

Camfil APC offers dust testing services and a fully equipped test lab that provides bench dust testing and ASHRAE Standard 199 testing.

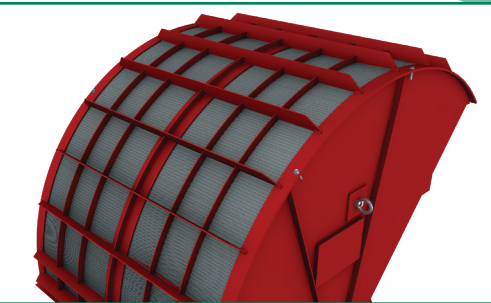

Flameless Vent

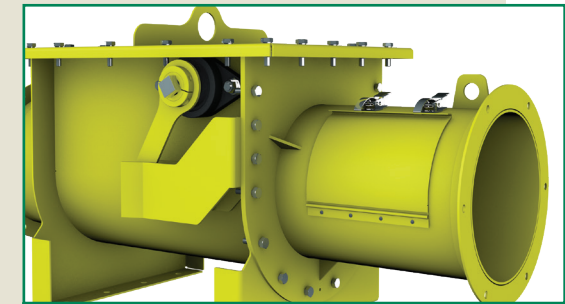

Stinger Valve

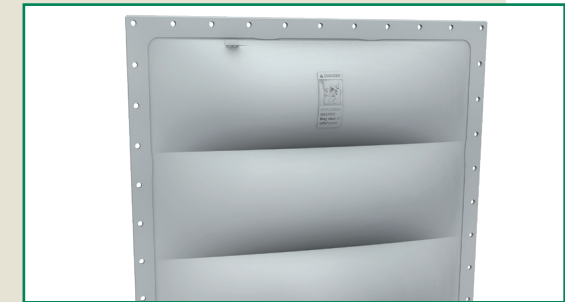

Deflagration Venting



Integrated Safety Monitoring Filter

The Power of Gold Cone™ X-Flo Filters

Gold Cone X-Flo (GCX) filter cartridges are the most advanced dust collector filters ever made. They feature proprietary HemiPleat® Gold Cone™ filters that stay cleaner and last longer than conventional pleated filters.

Each GCX filter contains 375 square feet of media, offering the industry's highest effective air-to-cloth ratio. This means fewer filters are required for a given application.

GCX filters were designed specifically for the Gold Series X-Flo dust collector. Used together, you get the most powerful and cost-efficient dust collection system on the market. The innovative system maximizes airflow while minimizing filter changeouts, compressed air usage, pressure drop and energy costs.

HemiPleat® Technology

HemiPleat technology is our unique method of creating highly efficient pleated filter media. Synthetic beads hold the pleats open and evenly spaced. Open uniform pleats expose more media to the airstream so that more dust is loaded on the filter and then released when pulse-cleaned. HemiPleat filters are far more efficient than standard filters.

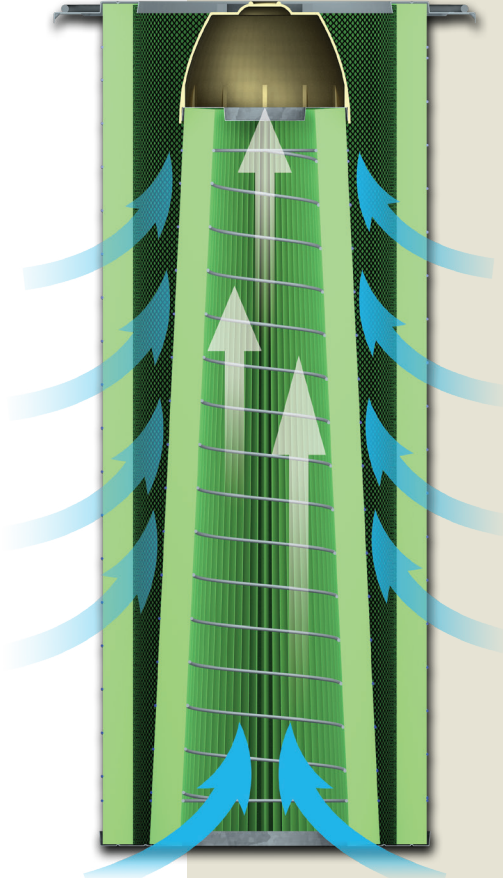

Air flows up through the open bottom of the filter cartridge.

Gold Cone™ Technology

GCX cartridges feature our proprietary Gold Cone inner pleat pack. This open-bottomed, inner cone of media greatly expands the usable surface area of cartridges. They stay cleaner and last longer than conventional pleated filters.

The inner cone is configured so that pulsed air is evenly distributed top to bottom along the outer pack of the filter and down through the inner cone pack. With each pulse, the X-Flo filter cartridge ejects more dust out of the collector than any other filter and helps maintain a low pressure drop.

More Downward-Facing Media

GCX filter cartridges are engineered to put dust in its place – into the collection bin where it belongs.

GCX filters, and their unique location in the collector, position more downward-facing media than any other system. 40% of each HemiPleat filter cartridge is focused on discharging collected dust straight down to the hopper. This offers a huge advantage over horizontal-style filters that pulse 90% of the dust back onto adjacent filters and only 10% into the hopper.

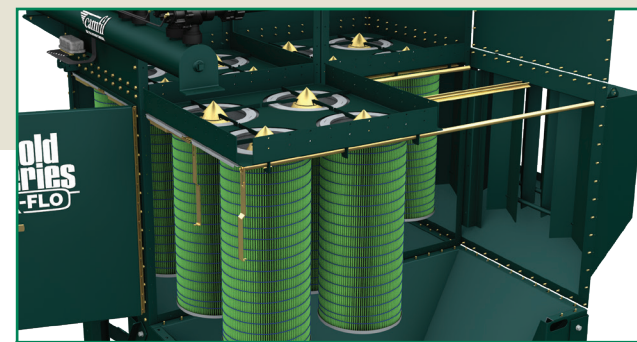

Filter cartridge placed in X-Flo Dust Collector

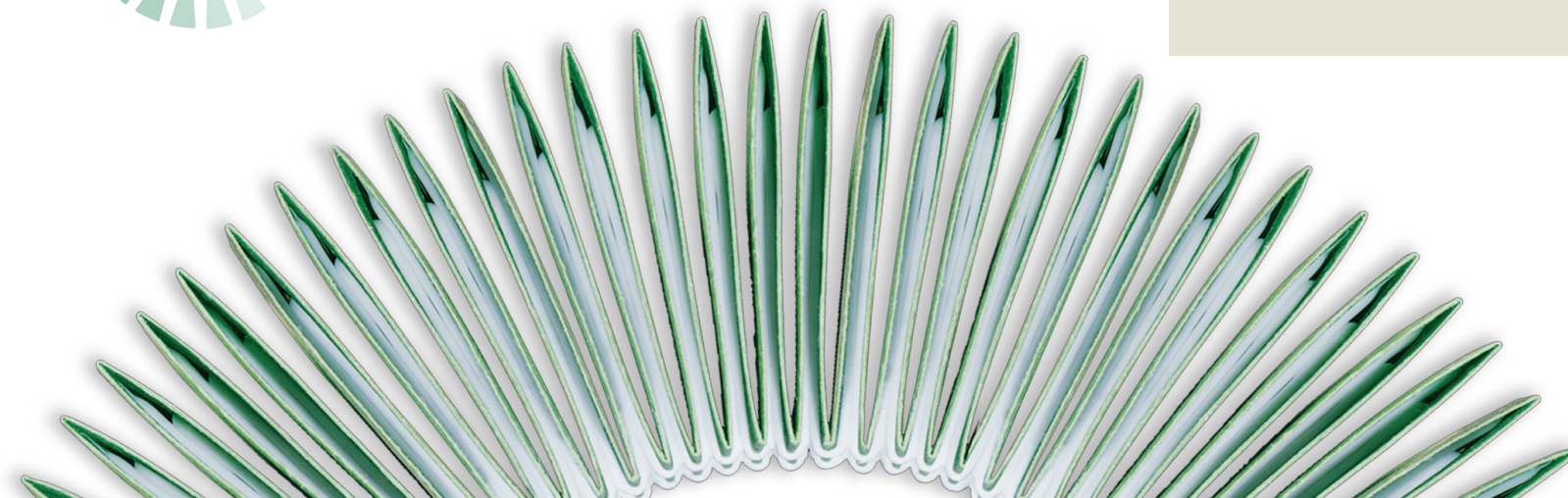

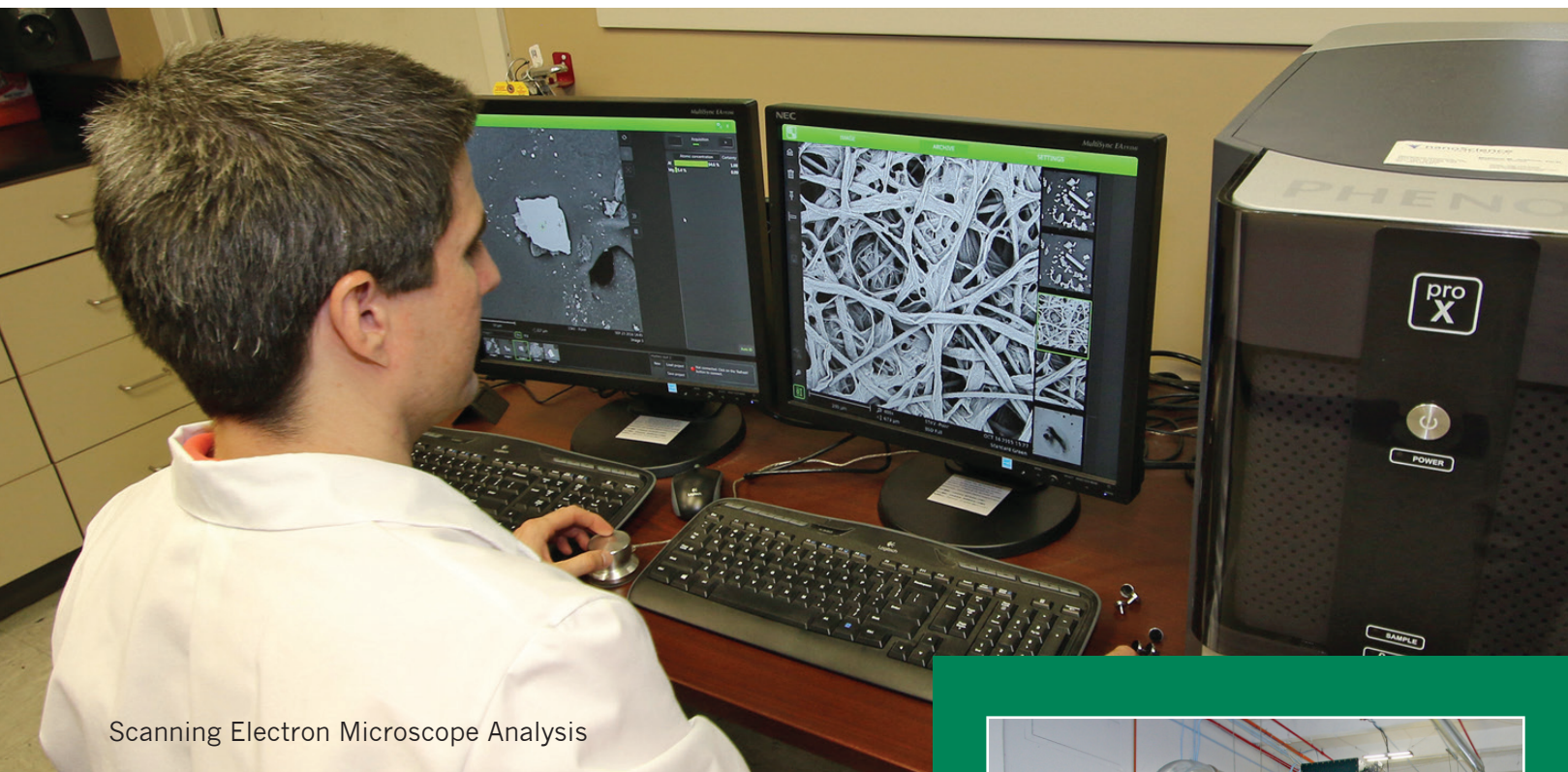

Scanning Electron Microscope Analysis

Camfil Cares

Camfil APC's industry-leading support services are branded "Camfil Cares" to encompass all we do to assess customer needs and recommend the most cost-effective equipment that complies with industry standards. Services include:

- **Site visits**
- **Prompt response to inquiries**
- **Providing specs to guide the budget and bid process**
- **Engineering, configuration and sizing of collectors to specific applications**
- **Dust testing**
- **ASHRAE 199 testing**
- **Expertise with OSHA, EPA, ATEX and NFPA regulations and standards**
- **NFPA compliance training**
- **Maintenance training**



ASHRAE Standard 199 Dust Test Apparatus



GSX collectors are engineered and sized for your specific application

Gold Series X-Flo Controls

Automatic Filter Cleaning and Energy Saving Controls

GSX Touch Screen Controller

This touch screen controller has energy efficient modes of operation and a flat menu structure that enables access to the most common parameters with the fewest clicks. The GSX controller easily accommodates eight languages and units, with a USB port to make software updates easy. The advanced section has multiple inputs that can trigger alarms for multiple external sensors and devices. Only two wires are required to connect the touchscreen and the pulse solenoids, regardless of the solenoid quantity.



VFD Controller

The timer controller with the Variable Frequency Drive (VFD) option provides complete control of the blower during and after startup. It has all the necessary functions for a controlled start without the high current loads typically associated with blowers. It also provides the ability to control the blower's speed, which provides energy savings and process functionality.

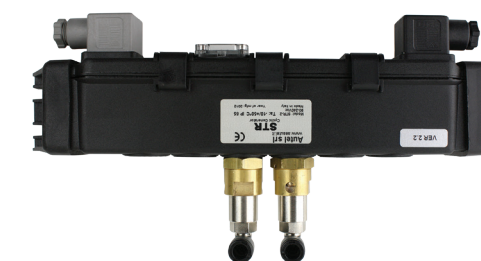

Smart Solenoid Controller

Timer controls for pulsing the solenoids are embedded with the solenoids. This means you no longer have to wire a remote timer board to the solenoid tray. The ON/OFF times are easily adjusted through dials integrated into the solenoid tray.



GSX Controller

This controller's flexible design allows it to be adapted to many dust collector configurations.



IDC Controller with Smart Start

Modular Construction To Fit Any Application

With Camfil's innovative design, it's fast and easy to get the precise configuration you need.



The modular design makes GSX collectors easy to build and assemble in limitless sizes and configurations. The modular design enables fast delivery of a system that is just right for your application and your space.



GSX modules ready for assembly

Gold Series X-Flo Models

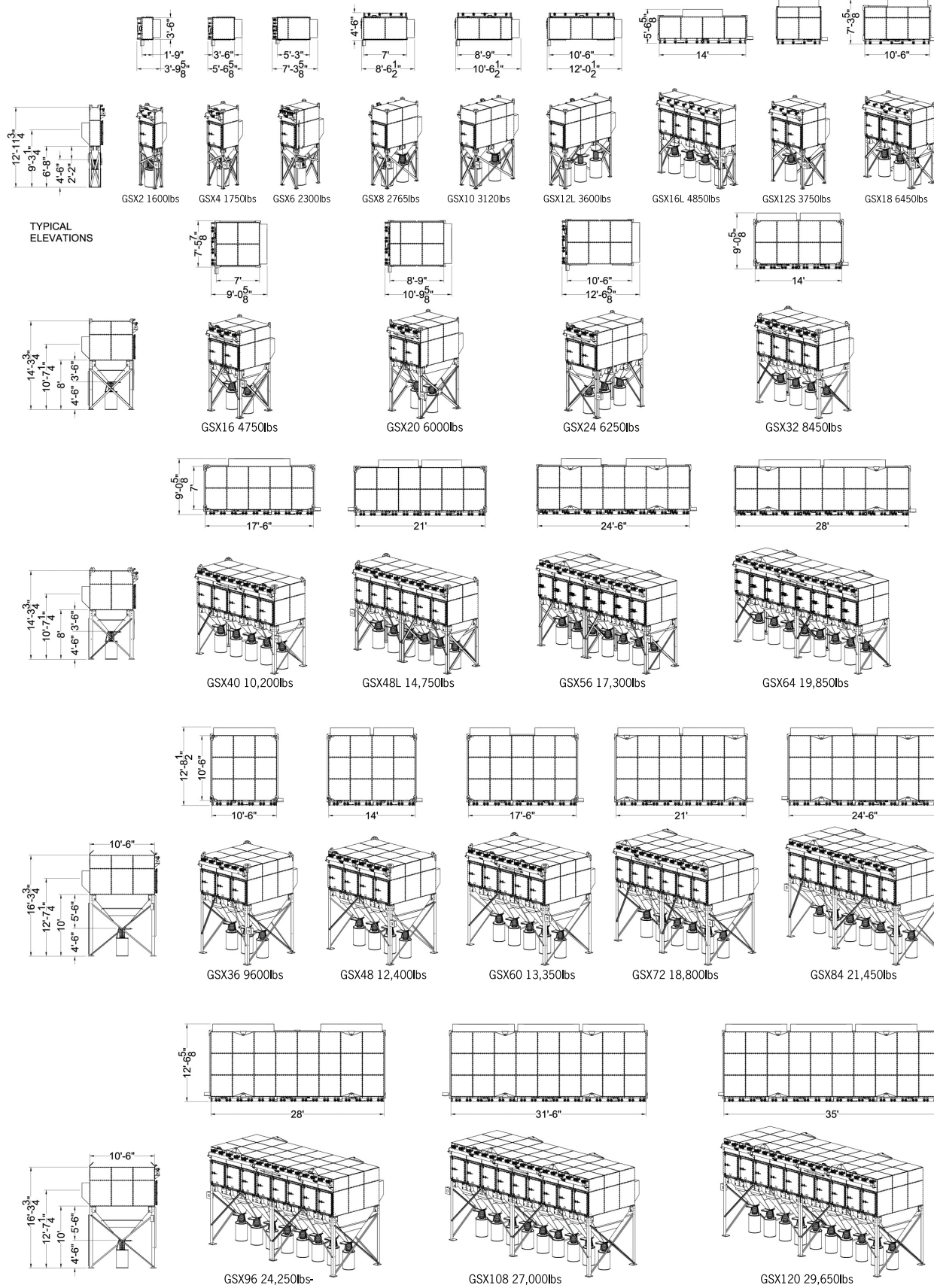

Model Code#
 GSX — # of cartridges
 24 — Gold Series X-Flo

Gold Series X-Flo Options

Pharmaceutical Options	Bag-In Bag-Out (BIBO) 	Butterfly Valve 	Continuous Liner Discharge 	Mining Options	Top Hand Rails 	UHMW Mining Inlet Baffle 	Slurry Tank for Conveying Dust 	Copper Tubing and Diaphragm Maintenance Valve 	Mining Options	
	Green Moisture Resistant Media 	Fire Retardant Media 	Carbon Static Electricity Conductive Media 		Synthetic Washable Media 					
Gold Cone X-Flo Media Options	Integrated Safety Monitoring Filter 	Sprinklers 	Deflagration Vent 	Deflagration Vent With Blast Plate 	Prevention of Fire and Dust Explosions	Vertical Deflagration Vent 	Flameless Deflagration Vent 	Stinger Backdraft Damper 	Chemical Suppression System 	Prevention of Fire and Dust Explosions
	Gold Cone X-Flo Media Options	Gold Cone X-Flo Media Options	Gold Cone X-Flo Media Options	Gold Cone X-Flo Media Options						

Gold Series X-FLO

Hopper Discharge Options



GSX Skirt

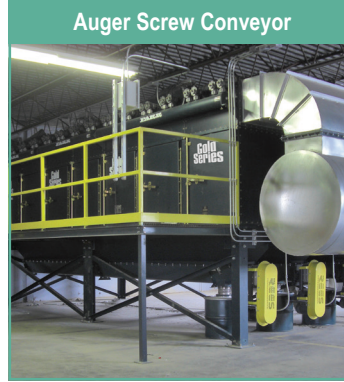

Auger Screw Conveyor

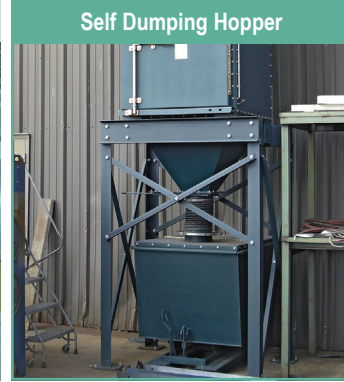

Self Dumping Hopper



Clean Sweep

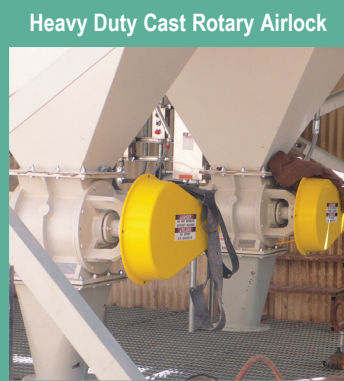

Heavy Duty Cast Rotary Airlock

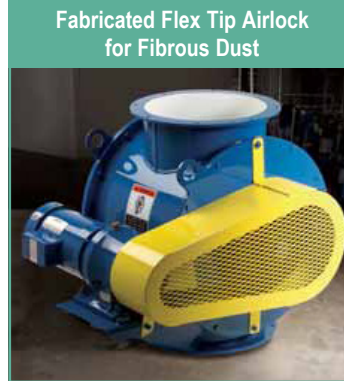

Fabricated Flex Tip Airlock for Fibrous Dust

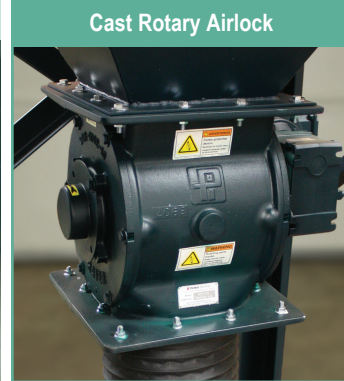

Cast Rotary Airlock

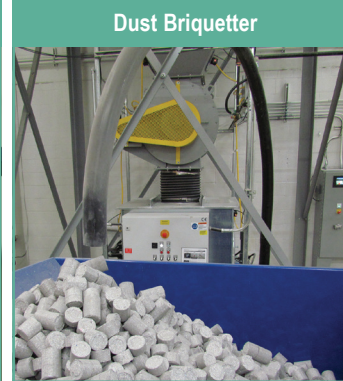

Dust Briquetter

Hopper Discharge Options

Ducting Designs

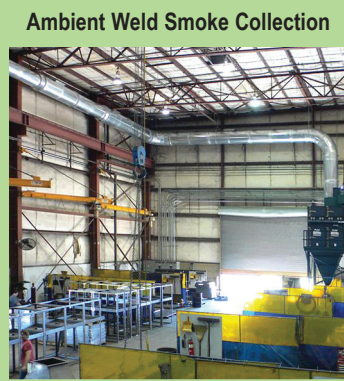

Ambient Weld Smoke Collection



Source Fume Collection

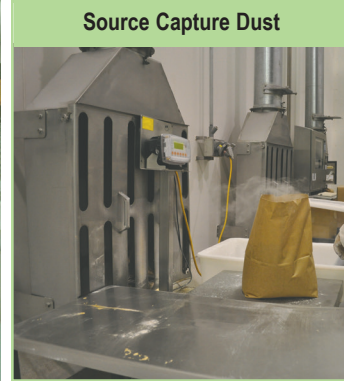

Source Capture Dust

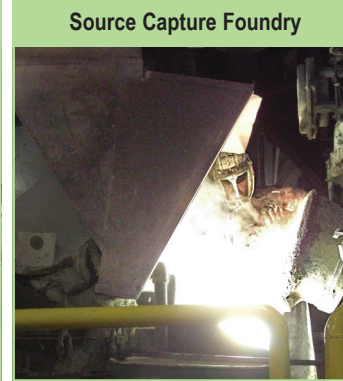

Source Capture Foundry

Ducting Designs

Fans



Top Mount Fan



Side Mount Fan

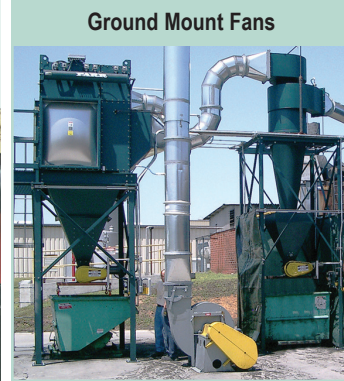

Ground Mount Fans



Fan Silencer

Fans



GSX Drum Kit with Slide Gate

Extended Options



Remote Safety Monitoring Filter

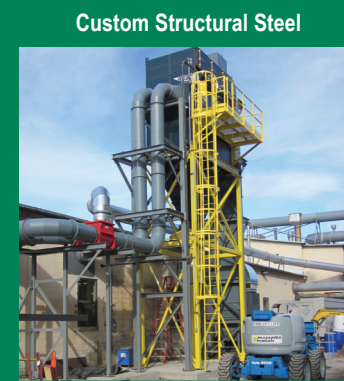

Custom Structural Steel

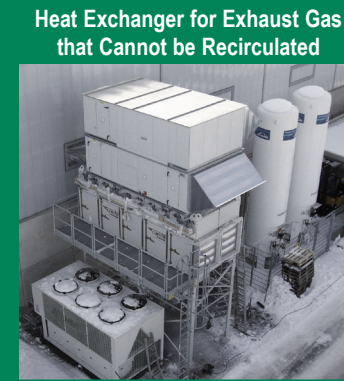

Heat Exchanger for Exhaust Gas that Cannot be Recirculated

Inlet Options



Drop Out Module



Broken Bag Detector



Quad Pulse Technology

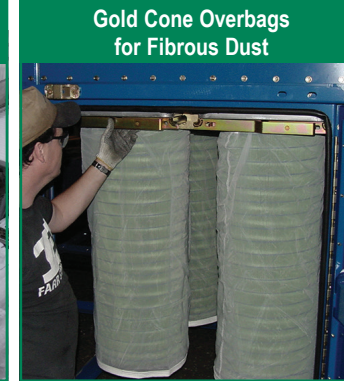

Gold Cone Overbags for Fibrous Dust

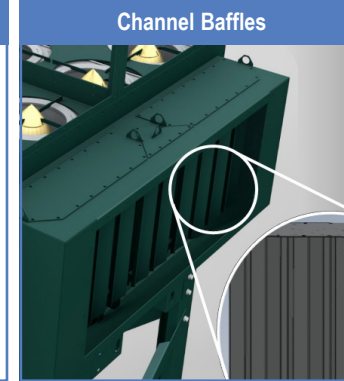

Channel Baffles



Collector Stiffening



Custom OEM Designs



Platform and Ladder

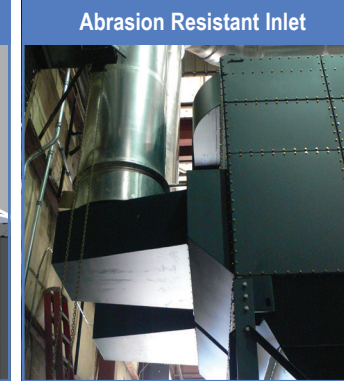

Abrasion Resistant Inlet

Extended Options

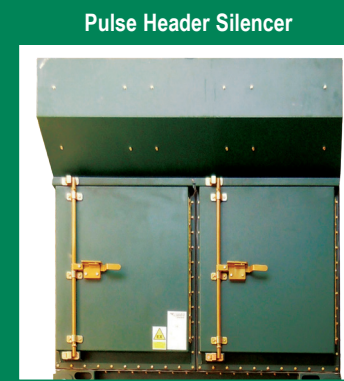

Pulse Header Silencer



GSX High Vacuum



Fully Insulated Collector



Stainless Steel



Compressed Air Regulator



Inspection View Port



Bin Vent

Extended Options



World's Largest Dust, Fume and Mist Collector Manufacturing Facility

25 acres - 280,000 square foot facility located in Jonesboro, Arkansas.



Jonesboro, Arkansas

Other Camfil APC Manufacturing Facilities



Taicang, China



Tuttlingen, Germany



Chomutov, Czech Republic

www.camfilapc.com

Camfil APC | 3505 S. Airport Road, Jonesboro, AR 72401
870-933-8048 | filterman@camfil.com | 800-479-6801